

PAUL N GARDNER COMPANY
9104 GUILFORD ROAD, SUITE H
COLUMBIA, MD 21046 USA

EMAIL GARDCO@ALTANA.COM
PHONE +1-954-946-9454



INSTRUCTIONS

GARDCO DISTRIBUTED PRODUCTS



The Barcol Impressor Hand-Held Portable Hardness Tester



Instruction Manual

The Impressor

Operation

The Impressor is intended for handheld testing of hardness for aluminum and aluminum alloys, soft metals, plastics, fiberglass, rubber and leather. Harder materials cannot be tested with the Impressor. For information on the available models, refer to the current revision of our product guide.

To test a surface, place the indenter point and the leg of the impressor on the same plane of the surface. To insure reading accuracy, make certain that no indentations from previous use are within 1/16th of an inch of the present indenter point position. Readings should not be taken on both sides of the 1/32nd inch-thick test disks. Readings taken on top of old indentations will adversely affect the accuracy of the reading. An ample supply of appropriate test disks should be maintained for these reasons.

Press down firmly, but carefully, on the impressor handle. Observe the indicator, noting the peak reading. For softer materials there will be some falling-off of the reading from the peak value. This is normal and is due to the nature of the materials being tested.

As a general rule, you should increase the number of readings taken as the softness of the materials being tested increases. Refer to the table below for recommended minimal numbers of readings for various materials using the Model GYZJ 934-1. Though specific numbers for Models GYZJ 935 and GYZJ 936 are not included due to correlation difficulties with softer materials, the numbers suggested for reinforced plastics serve as a starting point for softer materials.

Recommended Numbers of Reading for Model 934-1

	GYZJ-934-1 Reading Range	For an Average Variance of	Recommended Number of Readings
Homogeneous Material:	80	0.28	3
	70	0.28	4
	60	0.28	5
	50	0.28	6
	40	0.28	7
	30	0.28	8
	20	0.28	9
Reinforced Plastics:	70	0.72	5
	60	0.78	10
	50	0.75	16
	40	0.78	22
	30	0.77	29

The Impressor

Operation (continued)

The indenter point must always be perpendicular to the surface being tested. To maintain perpendicularity, the leg of the Impressor must be on the same plane as the indenter point, with both flats of the leg touching the same surface. Irregularly-shaped objects to be tested should be mounted in a holding jig to assure that perpendicularity is maintained. For flat objects, a temporary offset of the leg to accommodate the thickness of the part being tested can be obtained by placement of washers of appropriate thickness between the leg and the case of the impressor. Without perpendicularity, accuracy of the reading cannot be assured.

Maintenance

The Impressor is a precision mechanical instrument and should always be handled with care. The deflection indicator built-in to the Impressor has a normal reading of zero when not in use.

The Indenter Point has a tip precisely-machined to very small dimensions. It should be used with care to prevent damage. Avoid sliding or scraping the Indenter Point when it is in contact with the surface being tested. If the Indenter Point is damaged, it must be replaced with a new one. The Impressor ships with two spare Indenter Points.

WARNING

Do not attempt to regrind an Indenter Point when damaged! The mechanical dimensions of the Indenter Point determine the accuracy of readings and will create erroneous reading when reground.

To check the condition of the indenter point, first visually inspect it for damage. Then place the impressor on a hard, flat surface with the appropriate test disk positioned under the indenter point. Press the impressor handle down firmly, but carefully, to avoid sideways slippage of the indenter point. The reading on the indicator should be within the range of values stamped on the test disk. If it is not, refer to the calibration procedure below.

Replacing the Indenter Point

1. Clean the new indenter with alcohol.
2. Remove the two screws that hold the impressor case halves together (see Figure 1).
3. Lift out the frame while holding the spring sleeve in place (so it will not fall off) until it can be removed.
4. Loosen the plunger upper guide nut with the provided wrench until the cross-notched top lip protrudes above the frame.
5. Hold the impressor upside down (so the spring and plunger won't fall out), then loosen the locknut with the provided wrench and remove the lower plunger guide.
6. Replace the indenter point in the lower plunger guide, then re-install the lower plunger guide, leaving about 3/16 of an inch of thread protruding below the frame.
7. Tighten the lock nut, then operate the Impressor against a moderately hard surface 20 to 30 times in order to properly seat the indenter.
8. Tighten the plunger upper guide nut until its top is flush with the frame.
9. Calibrate the impressor per the procedure below.
10. Replace the spring sleeve, reassemble the case halves and screws, and test for the appropriate reading on the test disks.

The Impressor

Maintenance (continued)

Calibration Procedure

For the GYZJ-934-1:

1. Set the top adjustment nut about 1/16 inch below the top of the frame.
2. Calibrate against the 87/89 disk using the bottom adjustment nut.
3. Calibrate against the 43-48 disk using the top adjustment nut.
4. Repeat steps 2 and 3 until both readings are within specifications.

For the GYZJ-935 and GYZJ-936:

1. Set the top adjustment nut about even with the top of the frame.
2. Calibrate against the test disk using the bottom adjustment nut.

Test Disks for the Model 934-1

Use the GYZJ 250 test disk stamped 87/89 for the model GYZJ 934-1 in step 2 above. Then use the GYZJ 78 test disk labelled 43-48 in step 3. Iterate between these test disks until the optimum reading for both disks is obtained. This procedure will provide the optimum accuracy over the entire range of the 934-1. If optimized readings cannot be obtained on both test disks, it is an indication that the indenter point may be damaged. Replacement of the indenter point is recommended.

The above procedure can also be used between any two reference materials with known Barcol values at the extremes of a portion of the impressor reading range. Calibration at these known values will provide enhanced accuracy within that portion of the range, but not outside of that range.

Test Disk for the Model 935

Use the GYZJ 69 test disk stamped 87-89 for the Model GYZJ 935 in step 2 above.

Test Disk for the Model 936

Use the GYZJ 70 test disk stamped 48-50 for the model GYZJ 936 in step 2 above.

The Impressor

Specifications

Note: Physical characteristics of very soft materials are such that uniform correlation between different hardness measuring systems cannot be established. For this reason, conversion curves should be considered tentative. We recommend that impressor hardness limits for each material be established by test.

Typical Readings of Aluminum Alloys

Alloy and Temper:	1100-0	3003-0	3003H14	2024-0	5052-0	5052H14	6061T6	2024T3
GYZJ-934-1 reading:	35	42	56	60	62	75	80	85

Approximate Conversion Curves for GYZJ-934-1

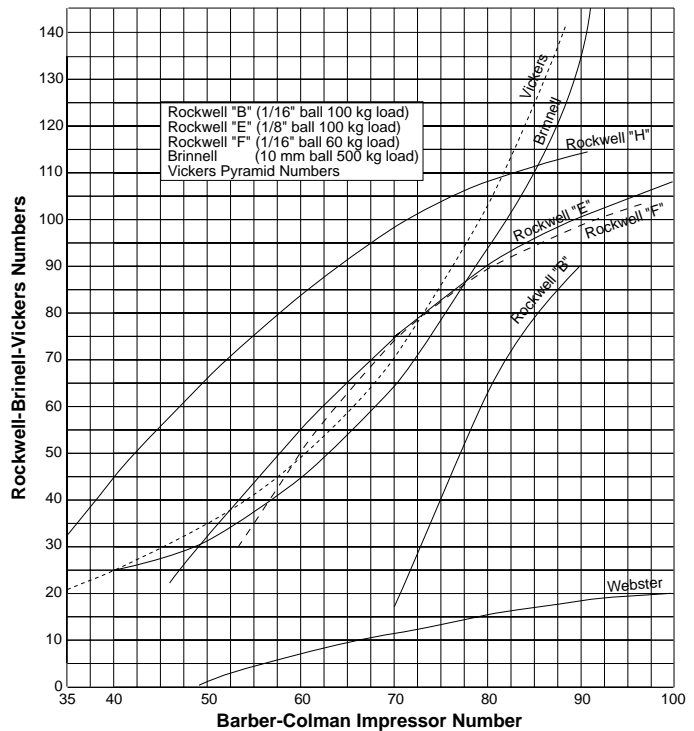

Approximate Conversion Curves for GYZJ-935 & GYZJ-936

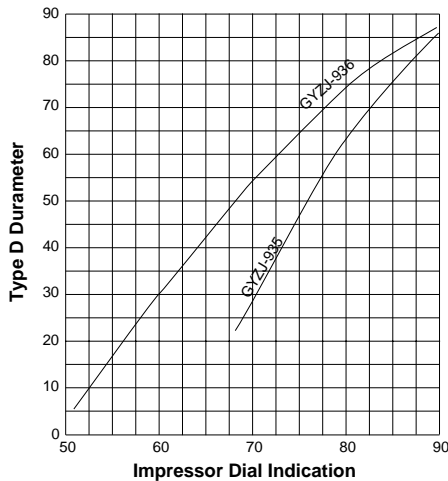

The Impressor

Operating Information (continued)

Approximate Conversion Chart for GYZJ-934-1

GYZJ-934-1	Brinell 10mm 500kg	Vickers 5kg	Webster Model B	Rockwell			
				B	E	F	H
35		21					32
36		22					35
37		23					37
38		24					40
39		25					42
40	25	26					45
41	25	27					47
42	26	28					49
43	27	29					51
44	27	30					54
45	28	30					56
46	29	31					58
47	30	32			23		60
48	30	33	0.7		26		62
49	31	34	1.3		28		64
50	32	35	1.9		31		66
51	33	36	2.5		34		68
52	34	38	3.1		36		70
53	35	39	3.6		39	30	72
54	37	40	4.2		41	34	73
55	38	41	4.7		44	37	75
56	39	43	5.3		46	40	77
57	40	44	5.8		48	43	78
58	42	45	6.3		50	46	80
59	43	47	6.8		53	48	82
60	45	49	7.3		55	51	83
61	46	50	7.8		57	54	85
62	48	52	8.3		59	56	86
63	50	54	8.8		61	59	88
64	51	56	9.2		63	61	89
65	53	58	9.7		65	63	90
66	55	60	10.1		67	66	92
67	57	62	10.6		69	68	93
68	60	65	11.0		71	70	94
69	62	67	11.4		73	72	95
70	64	70	11.8	17	75	74	97
71	67	72	12.2	23	76	75	98
72	69	75	12.6	28	78	77	99
73	72	78	12.9	33	80	79	100
74	75	81	13.3	38	81	80	101
75	78	85	13.7	42	83	82	102
76	80	88	14.0	47	84	83	103
77	84	92	14.3	51	86	85	104
78	87	95	14.7	55	87	86	105
79	90	99	15.0	59	89	88	106
80	94	103	15.3	63	90	89	106
81	97	108	15.6	66	91	90	107
82	101	112	15.9	70	92	91	108
83	105	117	16.2	73	94	92	109
84	109	121	16.4	76	95	93	109
85	113	126	16.7	79	96	94	110
86	117	131	16.9	81	97	95	111
87	121	137	17.2	84	98	96	111
88	126	142	17.4	86	99	97	112
89	130		17.6	88	100	98	112
90	135		17.8	90	101	98	113
91	140		18.0		102	99	114
92	145		18.2		103	100	
93			18.4		103	100	
94			18.6		104	101	
95			18.7		105	102	
96			18.9		106	102	
97			19.0		106	103	
98			19.2		107		
99			19.3		107		
100			19.4		108		

Approximate Conversion Chart for GYZJ-935 and GYZJ-936

Type D Durometer	GYZJ-935	GYZJ-936
52		6
53		9
54		12
55		15
56		18
57		21
58		24
59		27
60		30
61		32
62		35
63		38
64		40
65		43
66		45
67		48
68	22	50
69	26	52
70	30	54
71	34	57
72	38	59
73	41	61
74	45	63
75	48	65
76	51	67
77	54	69
78	57	70
79	60	72
80	63	74
81	66	76
82	69	77
83	71	79
84	74	80
85	76	82
86	79	83
87	81	85
88	83	86
89	85	87
90	87	88

The Impressor

Repair Parts

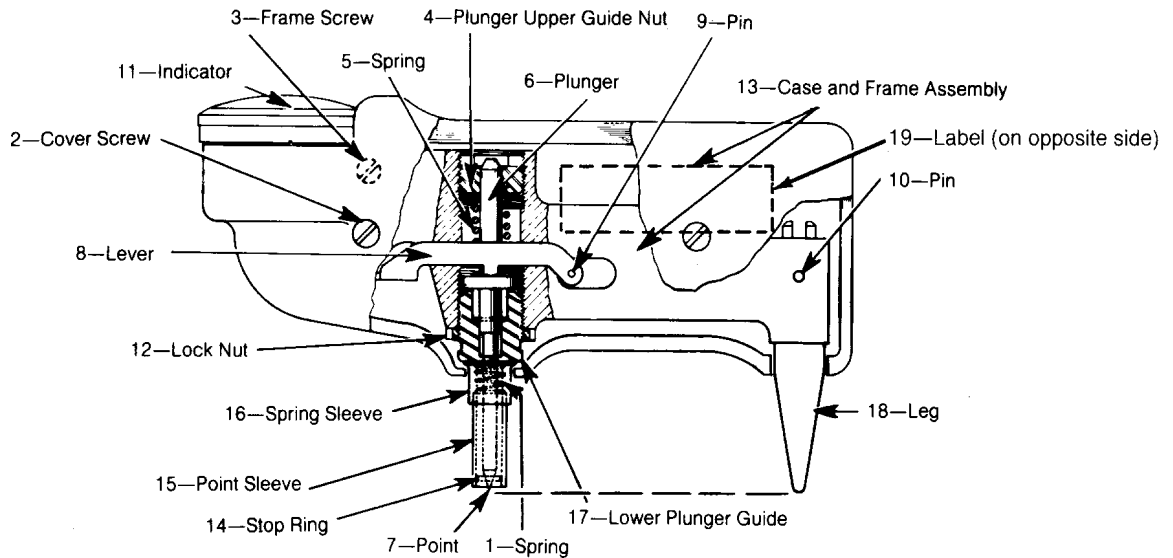

Figure 1. Impressor Cutaway

Contact factory (RPPL) for repair parts prices

Item	GYZJ-934-1	GYZJ-935	GYZJ-936	Description	Qty
1	AYRS-62	AYRS-62	AYRS-62	Spring	1
2	BYRF-3114	BYRF-3114	BYRF-3114	Cover Screw	2
3	BYRF-250	BYRF-250	BYRF-250	Frame Screw	1
4	GYZJ-2	GYZJ-2	GYZJ-2	Plunger Upper Guide Nut	1
5	GYZJ-3	AYRS-146-1	AYRS-146-1	Spring†	1
6	GYZJ-4-1	GYZJ-4-1	GYZJ-4-1	Plunger	1
7	GYZJ-6-5	GYZJ-6-5	GYZJ-67	Indenter Point†	1
8	GYZJ-7	GYZJ-7	GYZJ-7	Lever	1
9	GYZJ-8	GYZJ-8	GYZJ-8	Pin	1
10	DYRA-218	DYRA-218	DYRA-218	Pin	1
11	GYZJ-15-2	GYZJ-15-2	GYZJ-15-2	Indicator (not field servicable)	1
12	GYZJ-16	GYZJ-16	GYZJ-16	Lock Nut	1
-	GYZJ-17-1	GYZJ-17-1	GYZJ-17-1	Wrench	1
-	GYZJ-19-2	GYZJ-19-2	GYZJ-19-2	Carrying Case	1
13	GYZJ-23-1	GYZJ-23-1	GYZJ-23-1	Case & Frame Assembly	1
14	GYZJ-61	GYZJ-61	GYZJ-61	Stop Ring	1
15	GYZJ-62	GYZJ-62	GYZJ-62	Point Sleeve	1
16	GYZJ-63	GYZJ-63	GYZJ-63	Spring Sleeve	1
17	GYZJ-64	GYZJ-64	GYZJ-71	Lower Plunger Guide†	1
18	GYZJ-65	GYZJ-65	GYZJ-65	Leg	1
19	GYZJ-79-1	GYZJ-79-2	GYZJ-79-3	Label†	1

† Parts required to convert between models.

Hardness Tester

Model	Range
GYZJ-934-1	25 to 50 Brinell (10 mm ball 500 kg load)
GYZJ-935	For softer plastic and very soft metals
GYZJ-936	For extremely soft material

Certified Test Disks

<u>Part No.</u>		<u>Use with Model</u>	<u>Barber-Colman Scale</u>
GYZJ-069-100	Set of 5	GYZJ-935	87 – 89
GYZJ-070-100	Set of 5	GYZJ-936	48 – 50
GYZJ-078-100	Set of 5	GYZJ-934-1	43 – 48
GYZJ-250-100	Set of 5	GYZJ-934-1	87/89

Standard Test Disks

GYZJ-069	Each	GYZJ-935	87 – 89
GYZJ-070	Each	GYZJ-936	48 – 50
GYZJ-078	Each	GYZJ-934-1	43 – 48
GYZJ-250	Each	GYZJ-934-1	87/89