



Paul N. Gardner Company

WASHABILITY WEAR & FRICTION TESTER

Operating instructions for the
washability wear and friction tester,
Model V



Operating Instructions

GARDCO WASHABILITY, WEAR & FRICTION TESTER

VARIABLE SPEED MODELS (V)

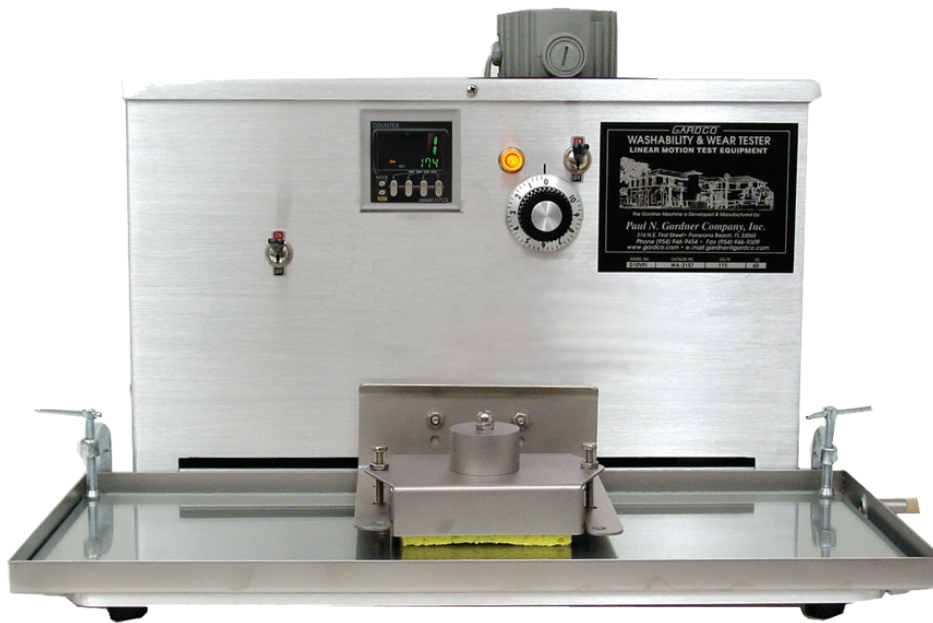

GARDCO
FRICITION - WEAR - WASHABILITY
LINEAR MOTION TEST EQUIPMENT
OPERATING INSTRUCTIONS
VARIABLE & VARIABLE FORCE MODELS



These instructions cover operation of the Gardco Linear Motion Equipment only. For test sample preparation and for use of machine auxiliaries with these samples refer to the appropriate standard method of test listed under Specification References of the product leaflet for this equipment.

Warning: Do not remove component case cover without first removing the unit electrical cord from the power outlet. As long as the unit is connected to the power outlet there are internal hot terminals even though the "power" switch is in the off position. If it is necessary to make component adjustments with the unit running it should be done only by a qualified electrician and one who is skilled in working in areas of unguarded pinch points. A system electrical diagram is included with operating instructions and a copy is contained in the cover of the component case cover.

1. Insure that the Power Switch is in the down (OFF) position. Plug the power cord into a 120 volt, AC power source. (220 volt if equipped with step down transformer).
2. Refer to the attached table for the representative Dial - Cycle Rate relationship and set the Rate Control dial at the desired value. (If a more accurate setting is desired, the operator should prepare a graph based on table #1 for his range of interest). Note attached instructions for minor adjustment of cycle rate limits.
3. Set the cycle counter to the desired number of cycles.
(See Cycle Counter Diagram on Next Page)
4. Secure the item to be evaluated in test position in accordance with appropriate standard testing procedure.
5. Place the Power Switch in the up (ON) position to start the test. The unit will cycle until the counter reaches the value set in Step 3 and then turn off automatically.
6. To start another test with the same number of cycles, place the Power Switch in the down (OFF) position. Repeat steps 4 and 5.
7. To start another test with a different number of cycles, place the Power Switch in the down (OFF) position. Repeat steps 3 through 5.

Easier to Read

For better readability, the character height for the present value display is 12 mm on models with 4 digits, the largest class in the industry. The wide viewing angle and brightness provide excellent visibility. The number of display segments has also been increased to make settings easier to understand, and the present value display can be switched between red, green, and orange so that output status can be seen from a distance.

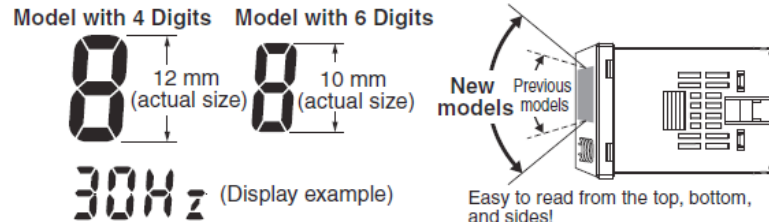

Note: The display color can be switched on all models except for the H7CX-A11 and H7CX-R11.

The Easiest Operation

Operation is simplified by the Up/Down Key for each digit on 4-digit models and Up Key for each digit on 6-digit models.

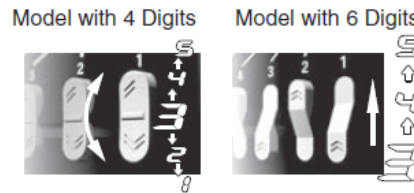

CAUTION: ALWAYS INSURE THAT THE POWER SWITCH IS IN THE DOWN (OFF) POSITION BEFORE RESETTING THE COUNTER.

Following each series of tests, place the Power Switch in the down (OFF) position, remove the power cord from the power outlet and clean the machine so that it is ready for future use. Any auxiliary used should be removed from the fork, cleaned and stored on its side. This is particularly important with the Brush Box and brush in order to preserve the initial straight conditions of the bristles.

All Gardco Linear Motion Machines are ruggedly designed and require minimum of maintenance. However, it is suggested that each year or following each 2,000 hours of operation, the chain should be oiled. This can best be done with the use of an artist brush by brushing oil directly on the chain rollers. A drop or two of oil should also be placed on the parallel bars and at each end of the "tail" sprocket bearings. If the chain becomes loose it should be tightened by adjusting the position of the "tail" sprocket support. If this adjustment is attempted, insure that proper alignment of the tail sprocket is maintained. Note: These maintenance procedures should be made only by experienced qualified personnel.

GARDCO LINEAR MOTION TEST EQUIPMENT



CYCLE RATE LIMITS ADJUSTMENT PROCEDURE APPLIES TO ALL VARIABLE CYCLE RATE MODELS

This procedure has been designed to verify the machine's expected cycle rate and provides specific instructions to make necessary adjustments.

WARNING: LETHAL VOLTAGES ARE PRESENT UNDER THE MACHINE'S CASE COVER. Do not remove the case cover without first removing the electrical cord from the power outlet. As long as the unit is connected to the power outlet there are internal hot terminals even though the "power" switch is in the off position.

WARNING: Any internal adjustments must be done by a qualified technician, one who is skilled in working in areas of unguarded pinch points.

Equipment Required



(1) Non-conductive Trimpot Alignment Tool



(1) Philips head screwdriver

Wiring Diagram

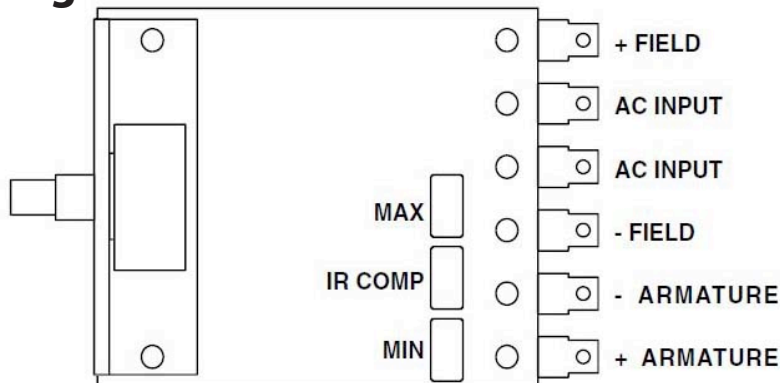
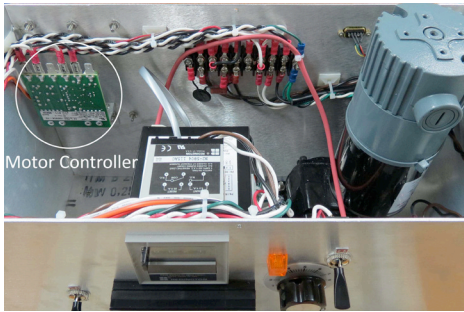

Figure 1 - Motor Controller Trimpots Location - Top View



The motor controller is, as shown in the picture, located in the left rear of the component enclosure. Adjustments on the controller are directly accessible by removal of the screws holding the component enclosure cover in place and removing the cover.

Maximum Cycle Rate Adjustment

If a maximum cycle rate different than that set at the factory is desired, adjust the maximum speed trim potentiometer as follows:

- Step 1 Turn the power switch to the "ON" position and set the speed to '9'.
- Step 2 Time and note the resulting cycle rate.
- Step 3 Using the Non-conductive Trimpot Alignment Tool with a 1/8" blade, adjust the maximum speed trim potentiometer (see Figure 1 - Motor Controller Trimpots Location - Top View) on the motor controller for the desired cycle rate.
- Step 4 Time and note the new cycle rate. Continue the adjustment until the desired cycle rate is obtained. Note: changing the max. cycle rate may change the minimum cycle rate

Minimum Cycle Rate Adjustment

If a minimum cycle rate different than that set at the factory is desired, adjust the minimum speed trim potentiometer as follows:

- Step 5 Turn the power switch to the "ON" position and set the speed control dial to '2'.
- Step 6 Time and note the resulting cycle rate.
- Step 7 Using the Non-conductive Trimpot Alignment Tool with a 1/8" blade, adjust the minimum speed trim potentiometer (see Figure 1 - Motor Controller Trimpots Location - Top View) on the motor controller for the desired cycle rate.
- Step 8 Time and note the new cycle rate. Continue the adjustment until the desired cycle rate is obtained. Note: Changing the minimum cycle rate may change the maximum cycle rate.

NOTE: Do not set the minimum cycle speed any slower than necessary.

TABLE #1
DIAL - CYCLE RATE TABLE

MODEL*	CYCLE RATE DIAL SETTING										
	0	1	2	3	4	5	6	7	8	9	10
	APPROXIMATE CYCLES PER MINUTE**										
D5.5V, VF, VFI	-	7	14	21	28	35	42	49	56	63	70
D7V, VF, VFI	-	7	14	21	28	35	42	49	56	63	70
D8V, VF, VFI	-	6.5	13	19.5	26	32.5	39	45.5	52	58.5	65
D9V, VF, VFI	-	6	12	18	24	30	36	42	48	54	60
D10V, VF, VFI	-	6	12	18	24	30	36	42	48	54	60
D12V, VF, VFI	-	5	10	15	20	25	30	35	40	45	50
D16V, VF, VFI	-	4.5	9	13.5	18	22.5	27	31.5	36	40.5	45

* This table applies to all variable speed models (V, VF & VFI).

** All values are in approximate cycles per minute.



CYCLE RATE - DRIVE FORK VELOCITY

REPRESENTATIVE RANGE SETTINGS

MODELS D10V, D10VF AND D10VFI

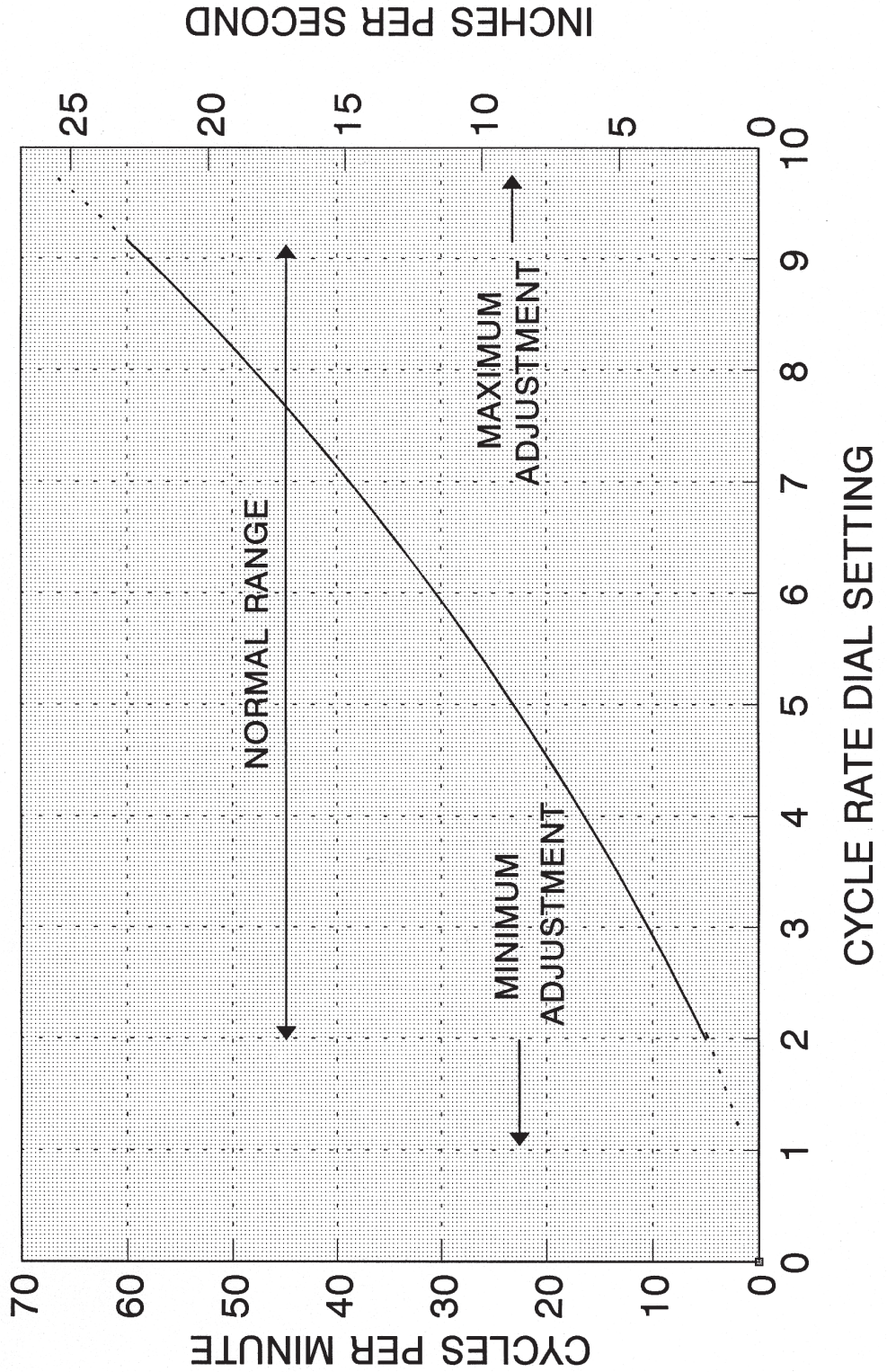

CYCLE RATE - DRIVE FORK VELOCITY

REPRESENTATIVE RANGE SETTINGS

MODELS D12V, D12VF AND D12VFI

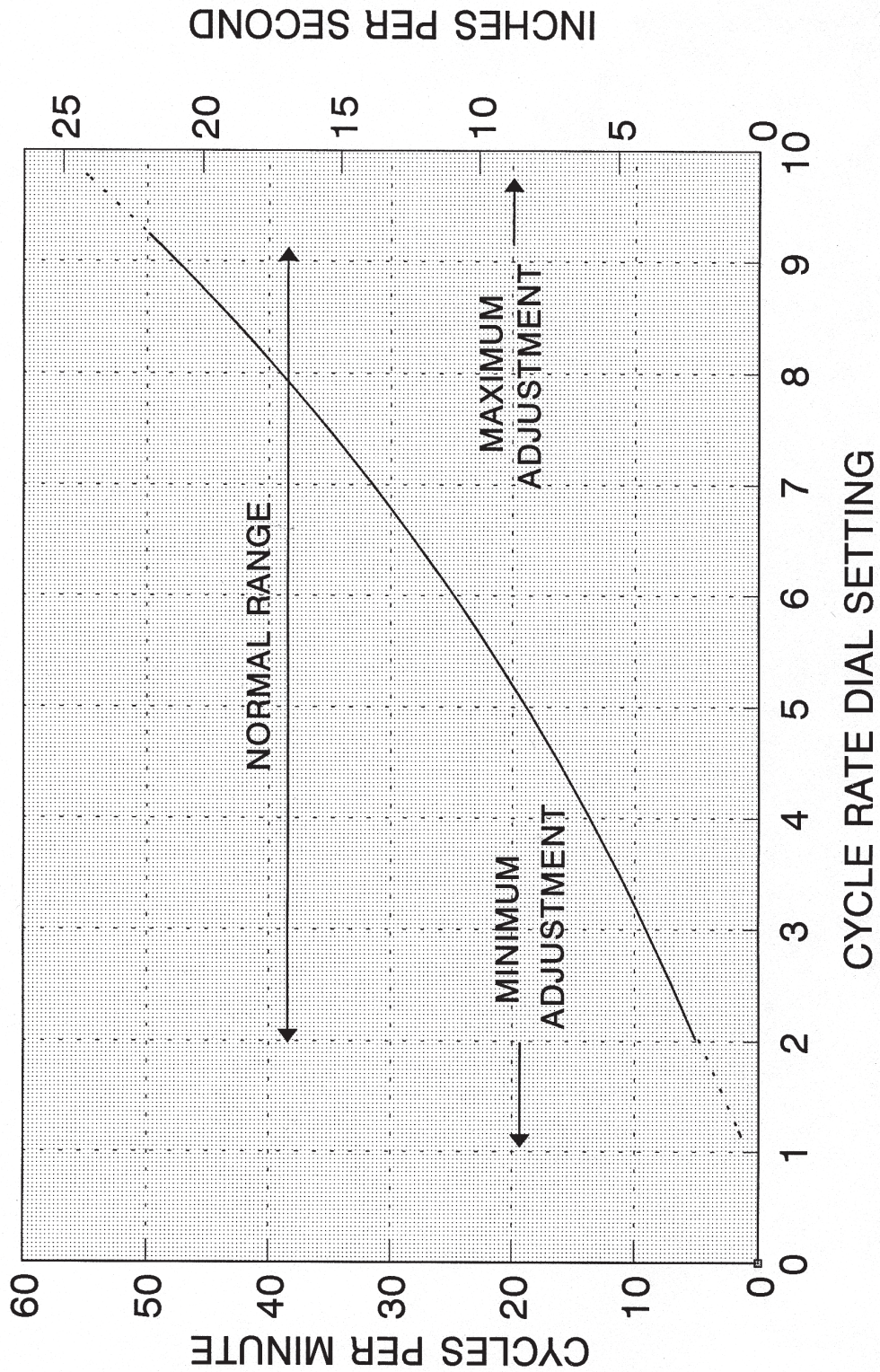

CYCLE RATE - DRIVE FORK VELOCITY

REPRESENTATIVE RANGE SETTINGS

MODELS D16V, D16VF AND D16VFI

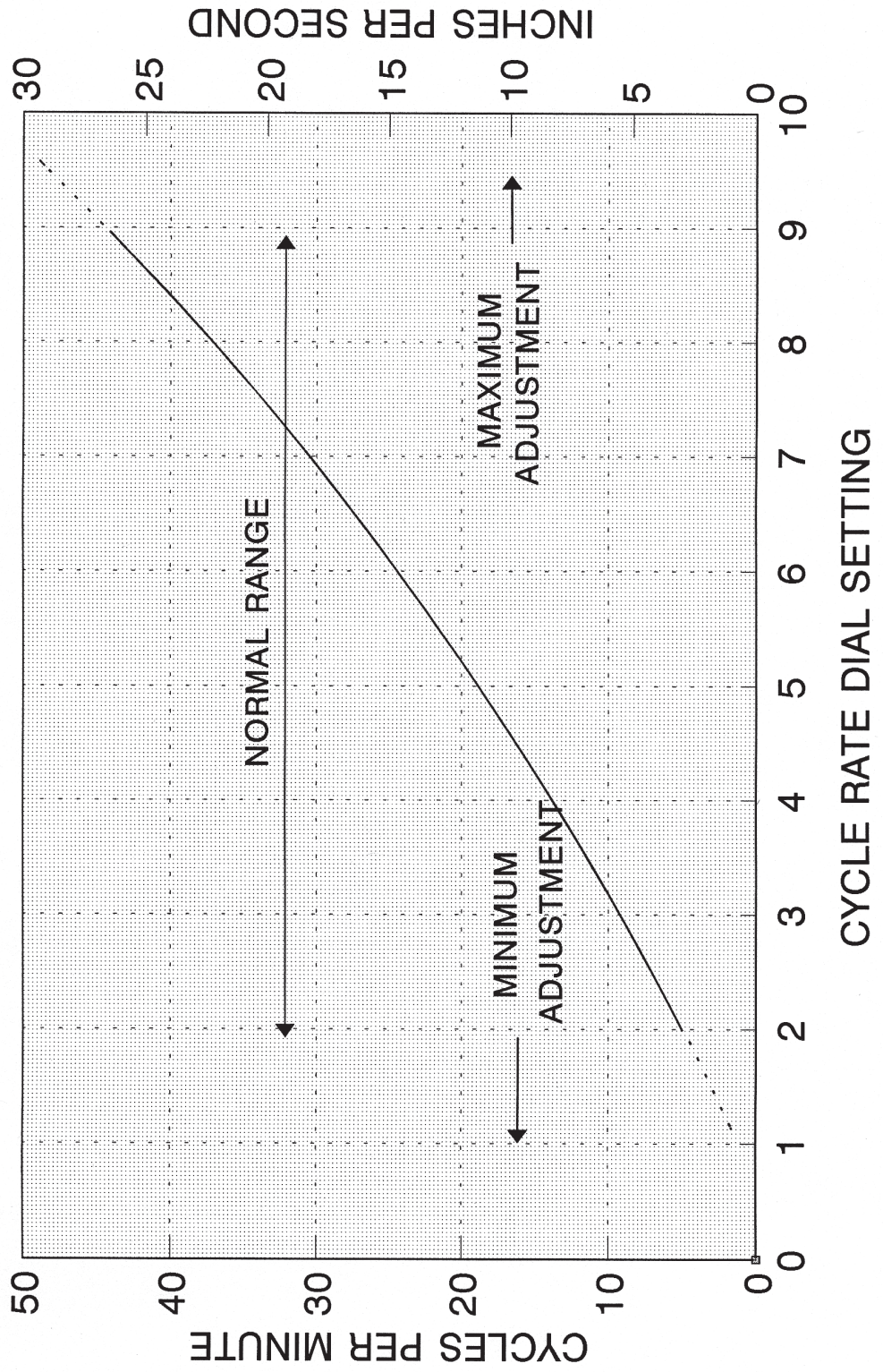



IMPORTANT NOTICE

ROLLER CHAIN ADJUSTMENT

GARDCO

WASHABILITY - WEAR - FRICTION

LINEAR MOTION TEST EQUIPMENT

All roller chains stretch with long, continued use. It is therefore, necessary to provide adjustment for chain tension in any mechanism using this product.

To insure against any movement of either the chain drive sprocket or tail sprocket supports during possible rough handling in shipment, both supports are pinned in place following proper initial adjustment. If chain tension adjustment becomes necessary after long continuous use, remove the two pins holding the tail sprocket support in place. This is done by driving the pins up through the base with an appropriate punch. Do not try to reinsert the pins following chain adjustment but insure that the bolts holding the tail sprocket support to the base are adequately tightened.

This precaution taken by GARDCO is another example of continuing engineering to provide the best possible equipment for the benefit of it's customers.



BRUSH BRISTLE CHARACTERISTICS

A REPORT FOR
PAUL N. GARDNER COMPANY

MAYNARD R. EUVERARD

BRUSH BRISTLE CHARACTERISTICS



A REPORT BY
Maynard R. Euverard

This is a report on work undertaken to evaluate characteristics of brushes designed specifically for use in washability machines. Such machines are referenced in ASTM methods relating to the cleaning and wear properties of coatings.

The work was requested by Paul N. Gardner, Sr., President of the Paul N. Gardner Company. Four brushes were furnished to be used in this work.

BRUSHES

Three of the brushes tested were new and one was used. The used brush bristles were worn to about 75% of their original length. There was some foreign material embedded in the base of the bristle tufts. The brush base was aluminum with the bristle tufts held in place by wire. The brush appeared to be built to conform to ASTM specifications.

One of the new brushes was of the same type as the described used brush. Stamped on the side of the brush was ASTM 2486.

The other new brushes were of identical design except one was made with hair bristles and the other with nylon bristles. The base of these brushes is plastic and the bristle tufts are cemented permanently in place. The brushes are designed to comply with ASTM specifications. A stainless steel plate, the size of the brush base is furnished with each brush to provide the same weight as the aluminum base brushes. The hair bristle brush is Gardco No. WA-2274 and the nylon bristle brush is Gardco No. WA-2272.

TESTING MACHINE

The apparatus used was Gardco Linear Test Equipment, Model D12VFI with associated recording equipment. This unit was adjusted to the lowest possible continuous, non pulsating, cycle rate which was 0.87 cycles per minute. All tests were conducted at this minimum setting except as specifically noted. The standard drive fork for operating in the stainless steel tray was used. Brushes tested were mounted in the standard brush box. The recorder was set for a high rate of paper feed.

Very rough sandpaper was secured in the right end of the machine tray with two sided pressure sensitive tape. Sandpaper used was 3M 36S R2. The sandpaper was cut to the width of the tray and to a length that provided a half inch of brush travel after the brush was completely on the sandpaper.

A preliminary investigation indicated that additional weight on the Brush Box exceeding two pounds caused the ASTM brush to "fall to the side" when slowly pulled on just the stainless steel tray. It was also learned that two pounds added to the brush box with the "Used" brush would stall the movement of the drive fork with the brush on the sandpaper. Note that the cycle rate chosen was considerably lower than recommended for this testing machine. As a result of this preliminary work it was decided to conduct tests on all four brushes without any auxiliary weight on the brush box and on the two new Gardco brushes with two pounds added.

The brush box was positioned at increased speed, when traveling from left to right to about a half inch from the brush entering the sandpaper and the speed was then reduced to the set minimum and at the same time the recorder was started. As soon as the machine registered a cycle count, near the end of the stroke at near the furthest travel to the right of the fork, a mark was placed on the recorder chart. The machine was permitted to continue in operation until it had moved the brush back onto the stainless tray surface, clearing the sandpaper by about a half inch at which time the recorder and fork travel were stopped.

A schematic of the recorder plot is shown in the attached computer drawing. This schematic also shows the measurements and calculations used for the data entered in the attached table.

On first study the element that appeared to be most consistent and also easiest to measure was the slope of the plot as the brush decelerated at the end of the stroke. Data was then entered in columns 1 and 2 of the attached table in order of highest to lowest "leading slope" (most flexible to least flexible bristles). The spread in data is almost three to one giving good resolution in the measurement. Note that the additional weight on the Gardco brushes did not change their order and changed very little their values.

Leading slope distance as a percent of left to right brush travel on the sandpaper is shown in column 3 of the table. There is the same relative order as in column 2 but the spread in values is somewhat smaller.

It was noted that the "trailing slope" of the recordings in all cases was much greater than the "leading slope". Why should this be? It also reverses the order of the new Gardco brushes and this is confirmed in both brush loadings but the ASTM brush is still by far the most flexible. A possible explanation is as the brush travels from left to right, the bristles align and nest uniformly as they pass over the edge of the sandpaper.

They retain this alignment throughout the left to right travel. At the end of the stroke, the individual bristles straighten and then start to flex in the opposite directions, without the earlier imposed alignment and nesting. Uneven bristle length could increase this effect. Column 4 shows the very much larger values of the trailing slope.

Column 5 of the attached table, Trailing Slope as Percent of total right to left travel of the brush on the sandpaper, as would be expected, places the brushes in the same order as column 4 but with an exaggerated difference between the new Gardco brushes.

Data in column 5 led to the calculation of the ratio of the leading and trailing slopes. Results are shown in column 6. Here, again, we have the exaggerated reversal of the new Gardco brushes and confirmed with both brush loadings. This leads me to believe that we are seeing a large difference of interfacial friction between these brushes and the sandpaper or a different packing of the individual fibers or range of fiber size.

Another element that can be observed in these tests is the force to move the brush over the sandpaper both in the left to right and in the right to left directions. The sum of these forces, without regard to sign, is shown in column 7. Here, the value is less for the more flexible ASTM brush than the two new Gardco brushes. The used brush with shorter bristles showing the greatest force. It is also noted in this column the effect of the additional weight on the Gardco brushes and that the additional weight caused a reversal in their listing order.

Finally, the force direction ratio was calculated and listed in column 8 of the attached table. In all cases, the force was greater with the motion from left to right than the motion from right to left. If the argument given above for the data in column 4 is valid, it may also apply to the results in column 8. An important observation is that this difference in column 8 largely disappeared on the new Gardco brushes as the load on the brushes was increased.

DATA INTERPRETATION

Care should be exercised in the interpretation of this preliminary data. In order to obtain apparent constant movement of the drive fork with the “used” brush in place it was necessary to increase the rate dial setting from 1.7 to 2.3. This is proportional to an unloaded cycle rate increase from 0.87 to about 2.4 cycles per minute. It is also possible that there were small undetected cycle rate variations in the testing of other brushes. It was this possibility that led to the use of ratios and percent of totals in the data of the attached table as this procedure minimizes such variations.

RECOMMENDATIONS

From what has been learned, I suggest the following for future additional investigations: Set the Linear Motion Machine to operate no slower than 2 cycles per second. Use a somewhat less course sandpaper than used in this series of tests. Wherever possible, use a one pound auxiliary weight on the brush box. Report values as shown in column 3 for bristle stiffness and in column 5 for possible other attributes of the bristles. It is probably not necessary to mark the chart when the machine registers a completed cycle as the change from a positive force to a negative force on the recording looks to be more accurate.

A copy of two of the tape recordings is attached to this report. This should be of value for machine setup in any future work.

SUMMARY

In summary, the equipment used is definitely capable of measuring comparative brush bristle stiffness. Data obtained indicates that there is capability of measuring other brush characteristics but additional work would be required for establishing the meaning of all the recorded data. This report is in considerable detail to assist anyone who may conduct further investigations.

For further information on the Model D12VFI Gardner Machine used in this report, phone or write to:

BRUSH BRISTLE FLEXIBILITY

TEST APPARATUS: LINEAR MOTION TESTER MODEL D12VF1 W/RECORDER
 BRUSH SUPPORT: STAINLESS STEEL TRAY TO COURSE SANDPAPER, 3M 36S R2
 CYCLE SPEED: 0.87 CYCLES PER MINUTE
 COLUMN DEFINITION: SEE ATTACHED SCHMETIC SKETCH

1	2	3	4	5	6	7	8
BRUSH	LEADING SLOPE	LEADING SLOPE % OF TOTAL	TRAILING SLOPE	TRAILING SLOPE % OF TOTAL	LEADING TRAILING RATIO	TOTAL MAXIMUM FORCE	FORCE DIRECTION RATIO
TOTAL WEIGHT ON BRISTLE TIPS, 1 POUND							
ASTM 2486	0.28	8.1	2.30	32	8.2	49	1.45
WA-2274*	0.22	6.5	0.97	12	4.4	56	1.43
WA-2272**	0.18	5.2	1.43	27	7.9	55	1.62
USED BRUSH	0.11	3.7	0.36	20	3.3	74	1.31
TOTAL WEIGHT ON BRISTLE TIPS, 3 POUNDS							
WA-2274*	0.21	4.9	0.75	13	3.6	73	1.09
WA-2272**	0.18	3.8	1.00	19	5.6	77	1.08

* HAIR BRISTLES
 ** NYLON BRISTLES

G2821BS1 PLG

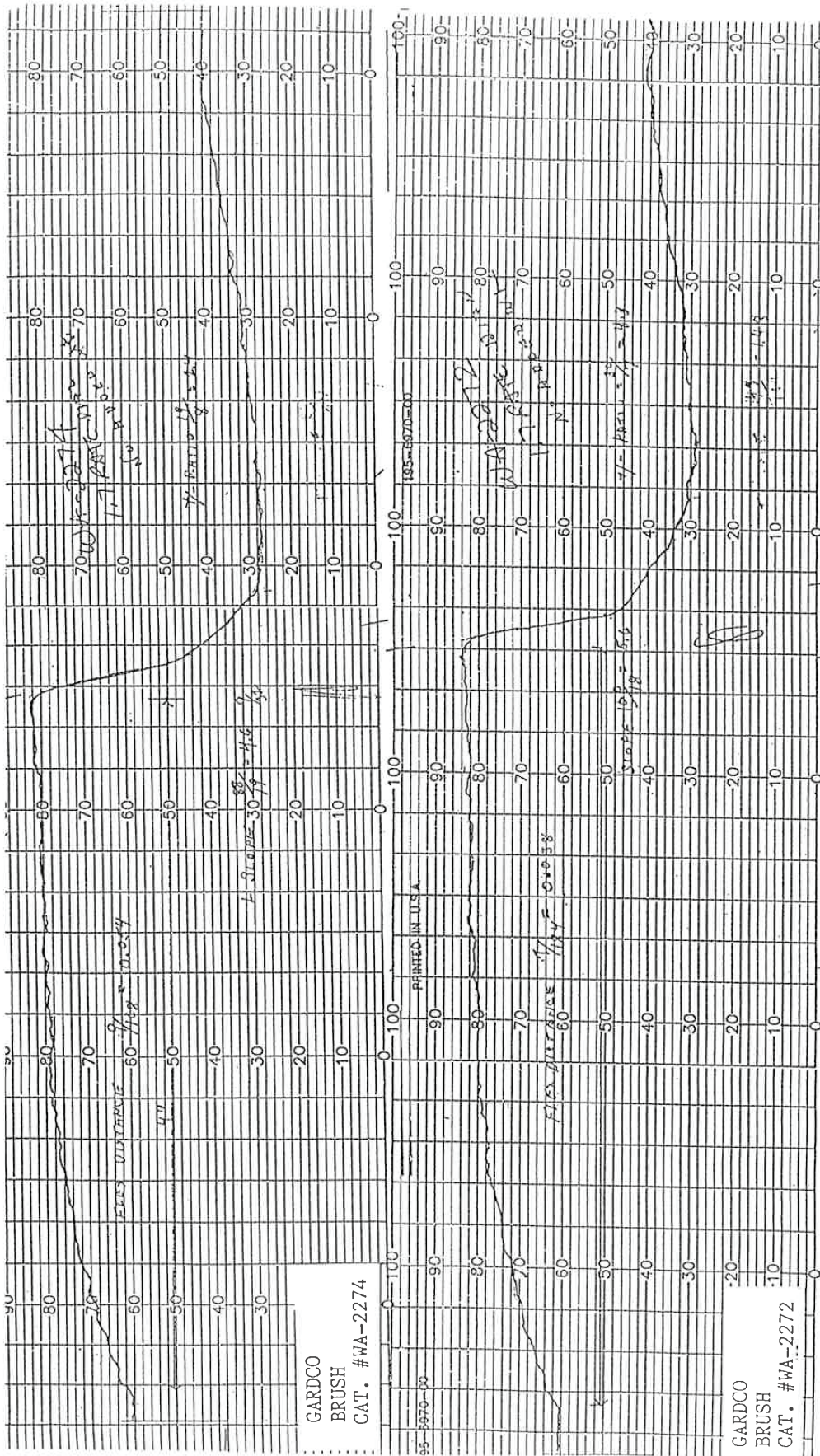

IMPORTANT NOTICE

For Your Own Protection

Do Not Throw Away This Box

This Crate was designed and built to safely transport this instrument and to comply with regulations for shipping. Save this box and internal blocking for re-use when the machine is returned for any service. Replacement crates cost up to \$600.00 USD.

Examine contents of this package at once for damage. If carton shows sign of damage, make notation on delivery receipt and request inspection by transportation company. Also, contact Paul N. Gardner Company (954-946-9454).

If damage cannot be detected until package is opened, call transportation company for inspection and get a concealed bad order report and contact Paul N. Gardner Company (954-946-9454).

Claims for damage, visible or concealed, must first be filed by you. We cannot assume responsibility for loss or breakage in transit.

OVER

**CUSTOM
SHIPPING CARTON**

DO NOT DISCARD

OVER